

Chapter 1

Introduction

1.1 Integrated Circuits

Integrated circuits are based on transistor logic, which means that logic gates (such as AND, NOT, NOR, EXOR, etc), resistors and other components are connected and packed together to achieve a specific function. This way we've been achieving, for a long time, small, for a long time, small circuits to build more complex circuitry using simple functions to build more complex systems.

For learning purposes students use those small circuits to build more complex systems. An easy example is to use several And Not gates to build an Adder or a Multiplier (Figure 1.1).

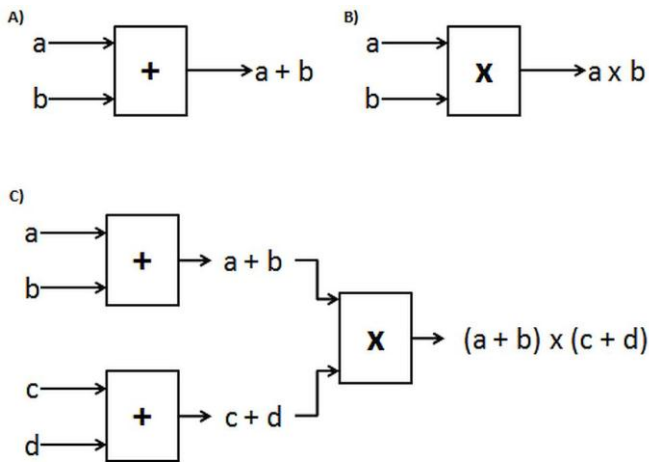

Figure 1.1 Examples of: A) Adder, B) Multiplier, C) Building bigger blocks: Adder and Multiplier.

In the process of building more complex circuit based on simpler ones, several questions arise: “Can all the circuits needed for a specific function be integrated into one single integrated circuit?” And, “is there a limit, in either size or technology, to build bigger and more complex integrated circuits?”

Well, the answer is yes. You can implement any mix of simple circuits to develop a more complex function, if you find it useful for a potential application. And, no, there is no limit for a design system, as long as you are willing to pay the design price for power consumption, circuit area, and speed.

The original purpose of the integrated circuits was to replace the bulky and energy hungry bulbs, so the initial functions were oriented to represent logic decisions, for example “if the door is open then activate the alarm”, or “if the motor speed is greater than 100, close the valve”. At this point, logic circuits have their size and energy consumption, so it was easier to have smaller and cooler control rooms making decisions over production processes. Then, what we can call the steady era, during the 80’s and 90’s, when the adders came along, multiplexers, encoders, memories and micro controllers. Everyone was fascinated about what they were able to achieve with those circuits. No one would have predicted what this area could become later, when information technologies and the internet modified all previous concepts about computing and processing. With the Information technology boom, came the data processing boom, in a way that more and more complex operations were needed, as well as communication protocols and the need for faster processing.

After these rapid growing technologies it is not easy to predict what will come next, but some approaches can be made. Silicon and transistor technologies are reaching their limit about minimum size and power consumption, which leads to other technologies being, explored (Figure 1.2). Maybe a totally new technology for circuits could come soon, and all of what we’ve known now should be reconsidered again. But that is what evolution is about.

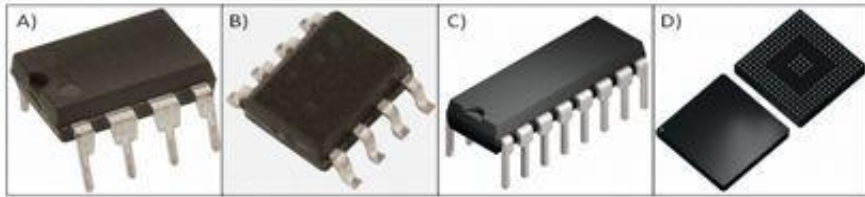

Figure 1.2 A) Memory EEPROM series 93C56C-I/P, B) Multiplexor AD8180ARZ, C) Encoders Priority SN74LS148N and D) Processors TMS320VC5510AGGWA2.

1.2 Digital and Analog Components

There is another classification for circuits according to the kind of signals and voltages it manages. Digital circuits are those which work on only two voltage levels, one level to represent a binary 1 and the other to represent a binary 0. All data and information in these circuits is represented, operated and stored, using 0's and 1's. Any value can be represented by a combination of 1's and 0's, and be interpreted back as the original value. Analog circuits contain signals in a wider and continuous range of voltages and currents, so physical variables such as temperature, pressure, volume, and speed can be represented by a scaled value. For example, a Temperature of 50 Celsius can be stated as a value of 10 if a scale of 0 to 50 is used for the range of 0 to 250 Celsius.

In this book most of the signals will be digital, except for some sensors and actuators that can work with analog signals. Each exception will be stated so there is no confusion.

1.3 Combinational and Sequential Circuits

Another circuit classification is based on how outputs are produced. According to the way a circuit delivers an output, either it is a signal, data, or a result; they are classified as Combinational and Sequential circuits.

Combinational circuit outputs do not depend on one another for the next output or result. This means that the moment when a function is performed does not change the result, because it does not depend on previous results or data from previous Actions.

Sequential circuits are time dependant; this means the result of their operation may be different depending on the moment a situation occurs. Specifically, a circuit that contains a program in the memory executes the program in a sequential way, and the outputs produced are taken into account for further operations.

1.4 Clocked or Timed Circuits

A lot of circuits require synchronization between systems or circuits; it means that several, or all, of the circuits involved in a bigger system should perform their operations at the same pace or rhythm, since they depend on each other's results in order to know what should be done next. In this circuit a clock marks the pace for the execution. A complex system may have one or several clocks, just as long as they remain synchronized for the intended purpose.

1.5 Circuit Size

Integrated circuits come in all sizes. The more gates or transistors are inside the circuit, the more complex the function would be, the larger the circuit looks on the outside, and the more pins are available on the external packaging. A general way to classify the circuits by size is as follows, having no precise boundary between sizes, but: SSI for Small Scale integration, MSI for Medium Scale Integration, LSI for Large Scale Integration, and VLSI for Very Large Scale Integration.

Something interesting happens when circuits become bigger and bigger. When you notice, as a circuit designer, that your circuit and functionality are getting more complex, you will probably conclude that you need a processor instead of individual circuits. After that thought, you lead to this next one: if I already have a processor in my design, could the same circuit be used in other applications other than the originally intended? The exciting answer is yes! A circuit, when it contains a processor, can be easily adapted to perform other functions, with small additions or modifications. Here is where circuit design becomes more interesting: Once you know how to design and implement a complex function using a processor within your integrated circuit, you are ready to implement any function you can imagine.

1.6 Design Process

Designing an integrated circuit starts as any project does: with the idea of what you want to develop. So you start saying something kind of like this: I want to have a circuit that takes anyone's age, weight and height, then it measures his temperature and blood pressure, and as a result it can predict how long the person

will live. Once you are able to state your intention in known words and clear intentions, you are ready to start designing it. The next step is to elaborate what you will need to measure, capture, calculate and process. For this example you will need: I will need a temperature sensor, a blood pressure sensor, a keyboard so the person can type his age and weight, a processor to run the calculations, a memory to store the calculation program, and a display to show the user the result. At this point you are describing your project in a very known and used way in this field: Inputs, functions, outputs. It means that you have acknowledged what data you need as input, what functions the system will be performing, in any case, everything will be easier if you can think of your idea in these terms: for each variable that my project needs, a sensor should be connected to it; the more complex the functions are, the longer the program will be; the more outputs the project will deliver, the more complex the display or interface will be. At this point, the clearer or more specific you can be on those three aspects (inputs, functions, outputs), the better. You will start from there until you get to the complete circuit, connections and elements.

A normal design process include iterations between what you want, what you achieve, what users say they need, and so on. Usually, the final implementation differs a lot from the initial circuit idea. We will discuss in detail the design process later.

1.7 Simulation Process

Once you have completed your design in paper, and your hand calculations show that it works as you want it to, a simulation is needed. You need a computer aided design tool to prove that what you are hoping to happen will happen. As in any other engineering field, there are many tools to learn and use.

For the purpose of this book, we will classify tools in Open source and licensed tools. Many universities pay licenses to software companies so their students have access to complex and professional tools. If that is your case, you can check with the system administrators what software they have for circuit design. If that is not your case and you are an independent designer, you can rely on open source code and simulators, since licensed software is never cheap and not worth it for a single design.

1.8 Implementation

Many enthusiast designers often risk their time and money by implementing their idea without the certainty that it will work properly, it means, without simulating it. It is up to you if you want to buy circuit components, sensors, and such, relying only on your hand calculations. The more complex your design is, the greater the possibility that it won't work as you expect it to work. After a successful simulation you have several options for implementing your design: If it's not intended for mass production you can use either the proto board version, which is cheap and good for prototyping, but only for small to medium circuits, or the FPGA version (Field Programmable Gate Array) which lets you know in a more accurate way the size, power consumption, transistor count, and speed of your circuit, when it becomes an integrated circuit. The development board version, allows you to store and run your program, check the output, connect your sensors, and test your program over and over until you are satisfied with the result. In the market you can find development boards for as low as 40 US dollars. The last option for implementing your circuit is to pack everything it needs into one single integrated circuit. This is what this book is all about: how to get a whole idea into one single integrated circuit. The best option for mass

production is an integrated circuit that contains everything it needs to perform its function. As you may notice, an integrated circuit is a final version of an idea, which you cannot modify it, has been fabricated. Nevertheless the circuitry and connections cannot be modified, but remember that if you put a memory inside your integrated circuit, and the memory has a program, and you were careful enough to consider a programming interface then you can modify the program in your circuit. Even it can serve as with different purposes if your design is made open enough.

1.9 Fabrication Process

Once you've finished your integrated circuit design you need to have the design in standard format files, so you can send these files to a fabrication company and then receive from them your shiny and brand new integrated circuits. Fabrication processes uses silicon wafers, and stamp your circuit on the silicon, so transistors and connections are made as you specified. Then the small piece of silicon is packed to protect it, adding pins for you to connect the circuit to whatever other system, sensors, or components it will be connected. Most of the well-known fabricants have University programs, in which they charge less for university projects, or let you join teams in order to split the fabrication costs. The fabrication process (Figure 1.3) involves “clean rooms” and very expensive equipment, as any dust particle, even if it is as small as a few nanometers, can get into the circuit, and produce a malfunction.

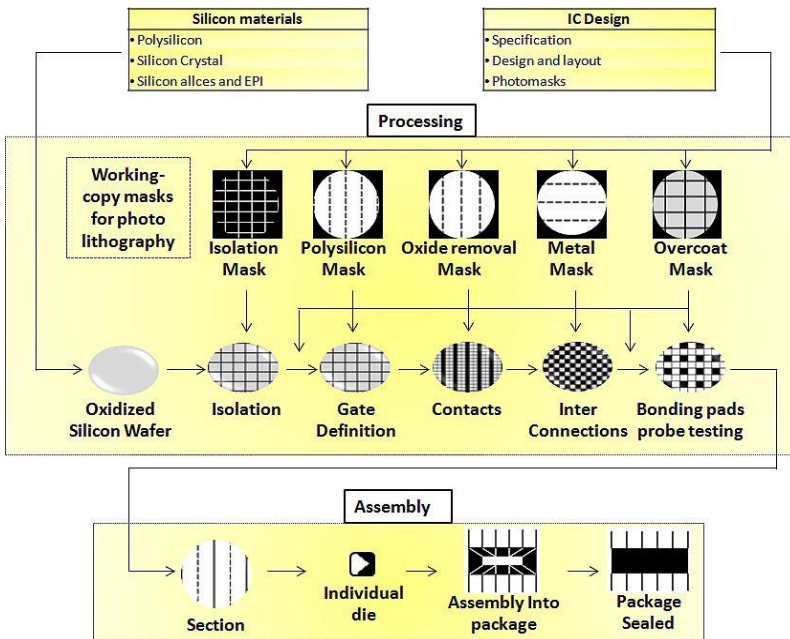

Figure 1.3 Fabrication process.

1.10 Marketing Process

In the beginning you intended your circuit for one purpose, so by now you probably know if it will be the main module of a stand-alone device, such as a microwave oven or a dishwasher machine. Having stated that integrated circuits that perform a specific function are intended for a specific device, you will need to get your circuit to the market, maybe not directly to the consumer, but to the device manufacturer.

